

AIR PLUG, AIR RING AND AIR CALIPER GAUGES



Air gauges are relatively low-cost, simple and easy to use. They are maintenance free and easy to set up to attain high accuracy measurement in a shop floor environment. Replacement gauges are substantially cheaper than alternative contact gauging methods and all air gauges come with the full back-up and resources of Coventry Gauge.

Air Gauge Elements and Setting Masters

Coventry Gauge Air Plug Gauges, Air Ring Gauges and Calipers are produced in steel, hard chrome and sprayed carbide. They link to electronic instruments and control via our CV5000 converter and benefit from the following features:

- High resolution
- High repeatability
- Non contact
- Static or dynamic measurement
- Multi parameter measurement
- 3mm to 150mm diameter
- Compatible with instruments from other sources

- Air plugs for internal measurement
- Air rings and Calipers for external measurement
- In-cycle, in process and post-process

Air Plug Gauges

Options:

- Through bore
- Blind bore
- Pilot entry groove
- 3 measuring jets
- Specials
- Steel, carbide, hardchrome, ceramic
- Handle and hose
- Connector

Masters:

High/low or nominal masters are required depending on read-out system, and should always be ordered with new air gauge elements.

Capabilities:

Depending on system specification, air gauges can resolve and repeat to sub-micron levels, and are capable of very high reproduceabilities even in shop-floor environments.

Full details of your application should be submitted to enable selection of the optimum read-out.

Small Air Plugs $\text{ØA} = 3\text{mm to } 8\text{mm}$

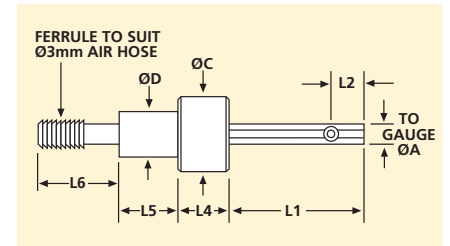

Air Plugs $\text{ØA} = 8\text{mm to } 150\text{mm}$

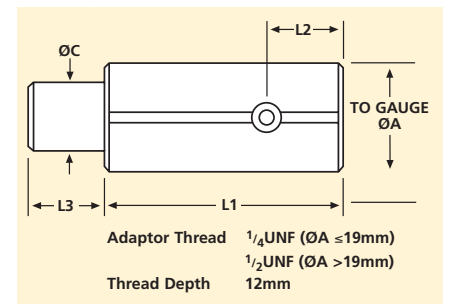

Jet diameter for Coventry Gauge Systems is 1.98mm or 1.16mm, depending on gauge diameter and jet position relative to front face. Other jet sizes are provided for other systems.

Adaptor for Air Plugs $\text{ØA} = 8\text{mm to } 150\text{mm}$

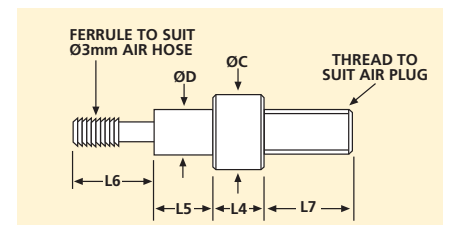

AIR PLUG GAUGES												
TO GAUGE ØA		L1		L2		ØC	ØD	L3	L4	L5	L6	L7
FROM	TO	THROUGH	BLIND	THROUGH	BLIND							
3.0	8.0	35.0	21.4	15.8	2.4	16	12.8	16	63	16	16	11
8.0	63.5	44.5	25.4	19.0	2.4	16	12.8	16	6.3	16	16	11
63.5	150.0	44.5	25.4	19.0	2.4	16	12.8	16	6.3	16	16	11

Air Ring Gauges

Options:

- Through bore
- Blind bore
- 3 measuring jets
- Specials
- Caliper configuration
- Steel, carbide body
- Mounting base

Masters:

High/low or nominal masters are required depending on read-out system, and should always be ordered with new air gauge elements.

Capabilities:

Depending on system specification air gauges can resolve and repeat to sub-micron levels, and are capable of very high reproduceabilities even in shop-floor environments.

Full details of your application should be submitted to enable selection of the optimum read-out.

Air Calipers

Used as a snap gauge for high resolution non-contact measurement, air calipers can also be configured to measure diameters in 2 or more positions along an axis, and at the same time, width.

Typical applications

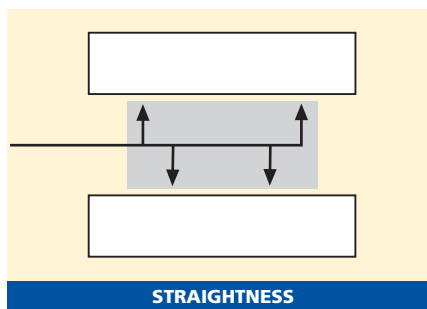

STRAIGHTNESS

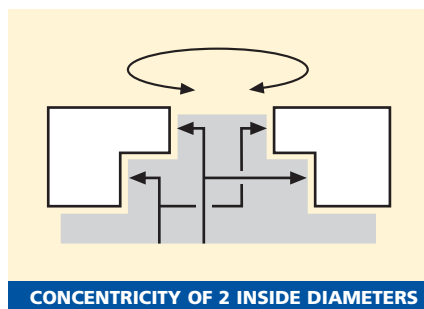

CONCENTRICITY OF 2 INSIDE DIAMETERS

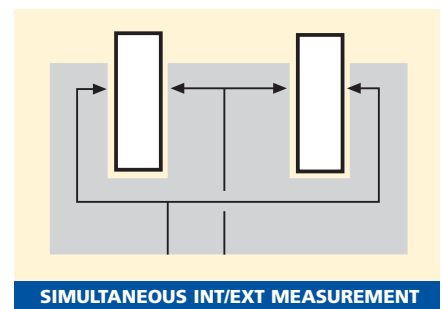

SIMULTANEOUS INT/EXT MEASUREMENT

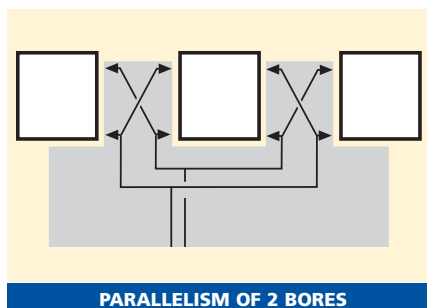

PARALLELISM OF 2 BORES

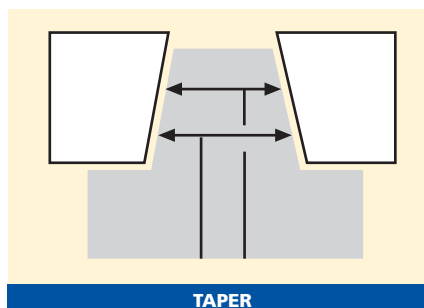

TAPER

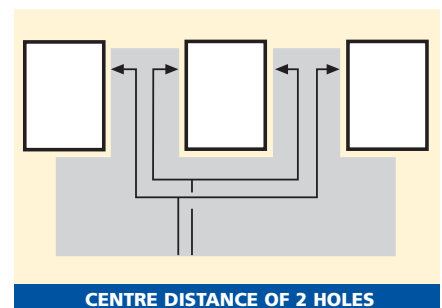

CENTRE DISTANCE OF 2 HOLES

AIR RING GAUGES						
TO GAUGE ØA		B		W		D
FROM	TO	THROUGH	BLIND	THROUGH	BLIND	
3.0	6.3	12.7	4.0	25.4	19.0	63.5
6.3	25.4	14.3	4.0	28.6	25.4	82.6
25.4	38.1	15.9	4.0	31.8	28.6	108.0
38.1	50.8	15.9	4.0	31.8	28.6	120.7
50.8	63.5	15.9	4.0	31.8	28.6	133.4

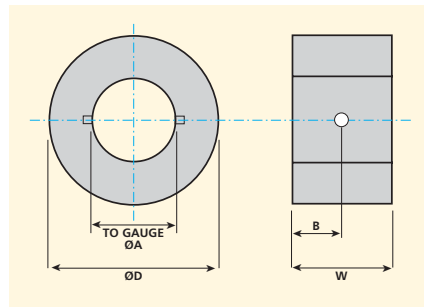

$JET\ \varnothing = 1.98mm$ or $1.16mm$, depending on diameter to be measured and position of jet relative to front face.

Air gauges can be engineered to be compatible with systems from Mercer, Federal, Sheffield and other suppliers for customers with these existing instruments.

Special Applications

As well as high precision gauging of holes and shafts, air gauging is often used to test features such as slot width, straightness, taper, concentricity, centre distance and displacement of one axis relative to another.

Air Gauge Read-Out Option

We will always recommend the best read-out option for the application. Selection criteria include cost, simplicity, data collection, accuracy, repeatability and reproduceability.

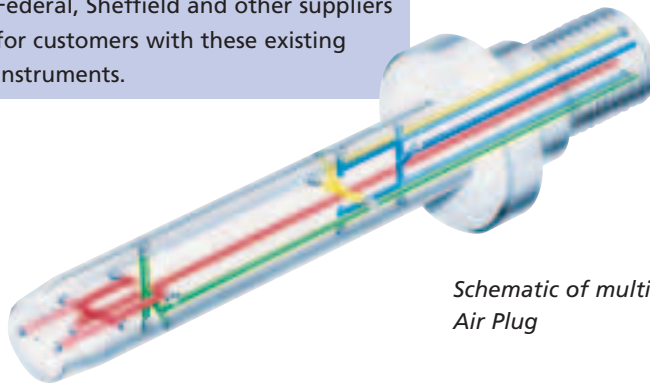

Schematic of multi-jet Air Plug



0002

Calibration Services available on all our products.